



IMPORTANT: Please take the time to read through the ENTIRE instructions prior to starting any work. Light Pipe material is very sharp when cut. Please use extreme caution when handling. **AVOID LEAVING THE PIPE EXPOSED TO THE SUN WITHOUT THE PROTECTIVE COATING OR DIFFUSERS IN PLACE PRIOR TO INSTALLATION.**

TOOLS/MATERIALS NEEDED

- Caulk
- Caulking Gun
- Driver & Bits
- Drywall Saw
- Flashlight
- Gloves
- Hammer
- Marking Pencil
- Measuring Tape
- Philips Screwdriver
- Reciprocating Saw
- Safety Goggles
- Stud Finder
- Tin Snips
- Utility Knife
- Wire

TUBULAR SKYLIGHT KIT PARTS:

- A.** Clear UV Protected, High Impact Acrylic Dome
- B.** (4) Phillips Head Stainless Steel ¼" Self-Tapping Screws
- C.** Black Nylon Horse Hair Gasket (self-adhesive)
- D.** Commercial Pure Grade Aluminum Flat Roof Flashing
- E.** (6) 1 ½" Phillips Head Stainless Steel Screws
- F.** Heavy Duty Foil Tape
- G.** (2) 24" Light Pipe Sections
- H.** White Nylon Horse Hair Gasket (self-adhesive)
- I.** (8) Phillips Head Stainless Steel ½" Self-Tapping Screws
- J.** (3) Black Speed Nuts
- K.** Ceiling Ring
- L.** (3) 1 ½" Flat Head Phillips Screws
- M.** High Impact Acrylic Diffuser
- N.** White Powder Coated Aluminum Trim Ring

PRECAUTIONS:

1. Ensure normal safety precautions are taken when using tools, ladder and walking on roofs.
2. Do not cut any structural members in the house.
3. Install only in dry weather.

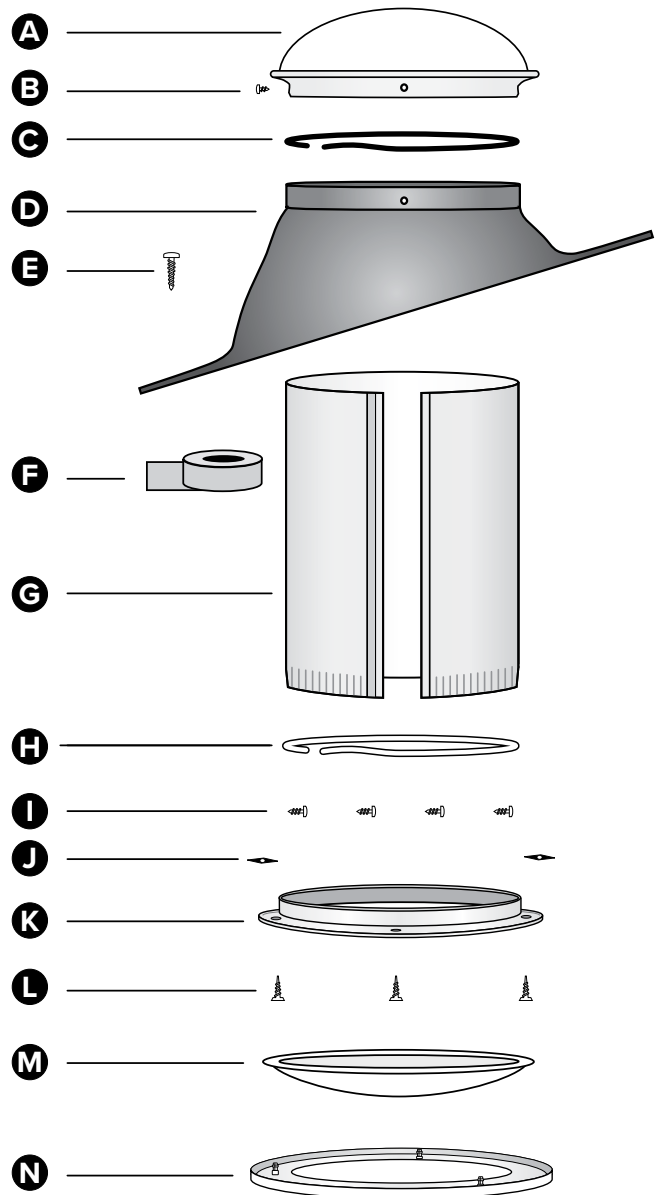

IMPORTANT INSTALLATION POINTERS – PLEASE READ BEFORE BEGINNING:

1. It is critical to plan the placement of the tubular skylight so that hole cut on roof and ceiling trim ring are aligned. Ensure that hole on roof is between framing trusses. **DO NOT CUT ANY STRUCTURAL FRAMING.**
2. When determining the location of the unit, southern exposure is recommended. Also consider potential problems such as objects shading the unit during certain times of the day.
3. Although adjustable elbows are available, straight light pipe runs result in higher light output and easier installation.
4. Prior to starting the job, **CUT PACKING STRAPS ON THE LIGHT PIPE AND UNCOIL THE TUBES.**
5. It's highly critical to check for obstructions above the ceiling which may hinder installation. If possible, visually check to ensure that there are no electrical wires or other obstructions where you plan to install the skylight. If you cannot check visually, use a piece of wire as outlined in Step 1.

STEP 1

Find the desired location for the ceiling trim ring and ensure that there are no obstructions in the attic space between the roof and ceiling. With a stud finder locate the ceiling joists and center the ceiling ring between joists as close to the desired installation area as possible. If you cannot check visually for obstructions, mark the center of the ceiling ring, drill a hole and insert piece of wire bent at a 90 degree angle. Rotate the wire around 360 degrees. While rotating, feel for resistance that could indicate wire runs or other obstructions.

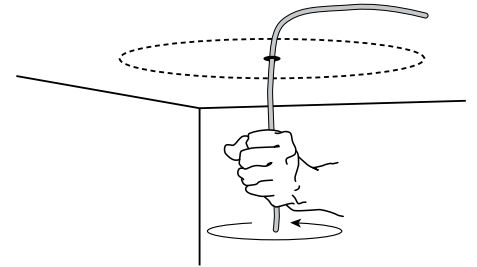

STEP 2

If there are no obstructions, scribe a mark around the ceiling ring (K), see diagram. Using a drywall saw, cut out the scribed mark in the ceiling.

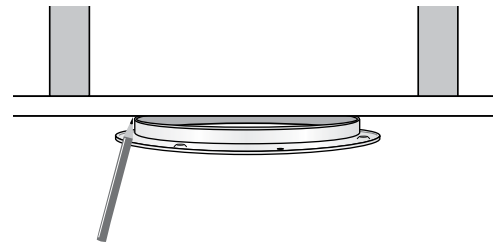

STEP 3

Peel the protective covering off the white horse hair gasket (H) and apply gasket to the INNER lip of the ceiling ring (K). This gasket ensures a dust free fit between the light pipe and the ceiling ring. Secure the ceiling ring to the ceiling by inserting a 1 1/2" flathead Philips screw (L) into one of the three pre-drilled holes and screwing it up through the drywall into the speed nut (J) provided. Repeat this process for all three screws.

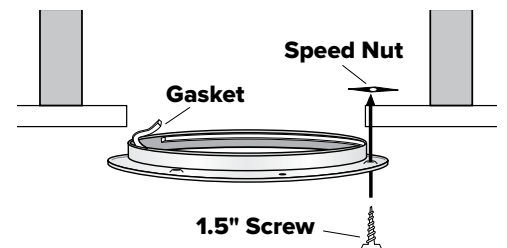

STEP 4

For the roof cutout, place a step ladder under the ceiling ring hole and place a flashlight on top of the ladder, the resulting flashlight beam will mark the location for the centering hole of the flashing unit on the roof. With a drill bit and appropriate extension rods, drill a pilot hole in the marked location on the bottom side of the roof. If there is access to the attic space, a plumb bob may also be used.

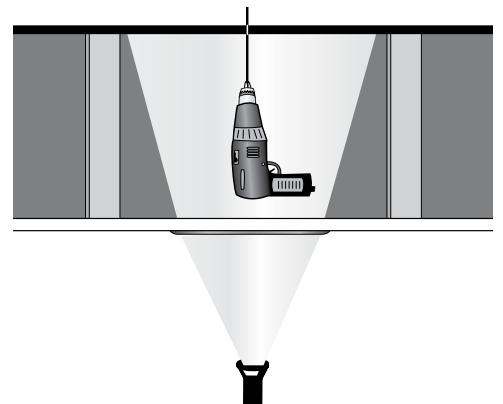

STEP 5

On the roof, locate the centering hole drilled in Step 4. Outline the diameter of the hole that the pipe will pass through by turning the flashing (D) upside down and marking the INSIDE lip of the flashing unit as shown.

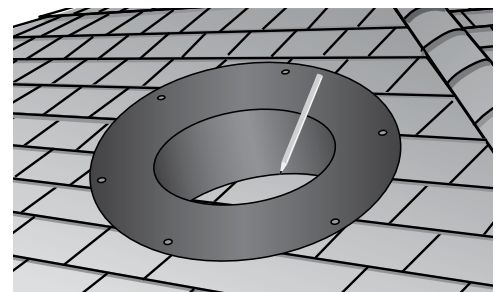

STEP 6

With a reciprocating saw, cut the diameter of the hole a **MINIMUM OF 1" LARGER** than the area marked in previous step.

NOTE: A larger hole can be cut to accommodate angled pipe installations.

IMPORTANT: The light pipe must pass between the roof rafters. **DO NOT CUT THROUGH ANY FRAMING MEMBER.**

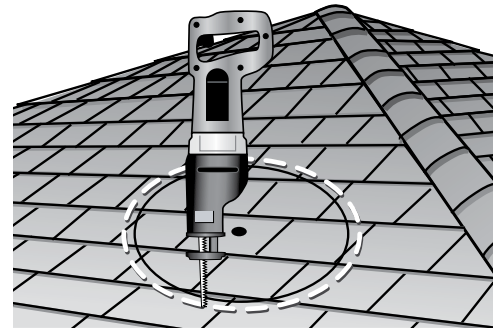

STEP 7

With a utility knife, cut a 4" slit through the shingles and tar paper at the 3 and 9 o'clock positions of the flashing. This allows for the footprint of the flashing to be inserted under the shingles.

NOTE: Additional shingles may also need to be removed on the high side towards the ridge to allow the flashing to slide over the hole (see inset).

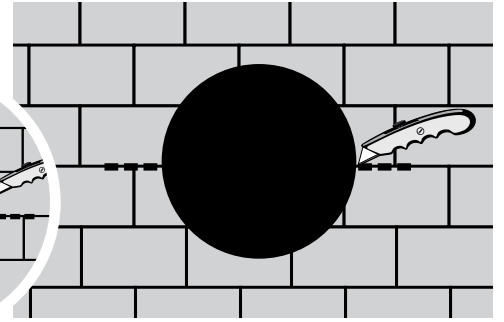
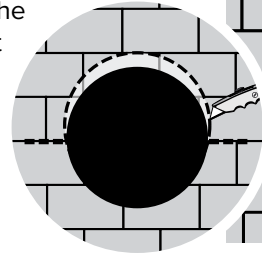

STEP 8

Insert the reciprocating saw blade sideways at the 3 o'clock position and start cutting the roofing nails up and around to the 9 o'clock position. This process removes nails that prevent flashing footprint from sliding up underneath shingles.

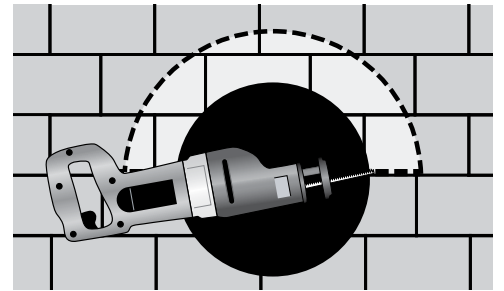

STEP 9

Caulk the underside of the flashing (**D**) with caulk. Two concentric rings of caulking material is sufficient.

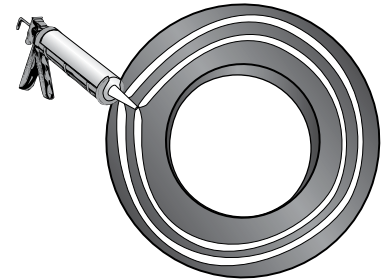

STEP 10

Taking care not to smear caulk on the exposed shingles, slide the flashing under the tar paper and shingles and force flashing up until the shingles come in contact with the raised portion of the flashing. The bottom side of the flashing will be on top of the shingles.

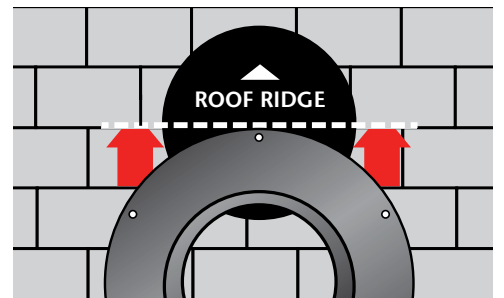

STEP 11

Secure the flashing to the roof with the Phillips head 1 1/2" screws (**E**) provided. Evenly space the screws around the lip of the flashing. Apply caulk over all exposed screw heads (since they will be exposed to the weather). Use remaining caulk to seal the areas where the 4" slits were made in Step 7 and around where the shingles meet with the raised area of the flashing.

